

CONTROL

ICC TOUCHSCREEN. ADVANCED QUALITY CONTROL AND QUICK RUN UP TIME.

UC STRAIGHTFORWARD CRIMPING CONTROLLING.



NC30ZUC

FINN-POWER NC30 AND NC40Z CRIMPING MACHINES FOR SERIAL PRODUCTION

NC30Z AND NC40Z – FAST AND ACCURATE

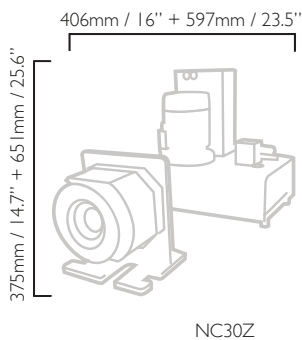

NC30Z

Finn-Power NC30Z and NC40Z nut crimping machines provide fast and accurate operation in crimping the nut, ferrule, bush set on ends of hydraulic hoses. A special centering pin, which is selected according to ferrule size, is used during the crimping. The machine produces accurate and consistent results. NC40ZUC is intended for use in automatic lines or applications for serial manufacturing.

OPTIONS

- Foot pedal
- Mechanical backstop device
- Auto greasing G3
- Remote control unit
- A3 signal option
- Pressure crimping (UC1, ICC1)
- Step crimping (UC2, ICC2)
- Quality crimping (UC3, ICC3)
- Graphical quality crimping (ICC4)

DIE SET TABLE NC20

Pno	Crimp. range	D	L
18546/12	12.0 - 16.0	12	3
18546/16	16.0 - 22.0	16	4
18546/22	22.0 - 27.0	22	4.5
18546/27	27.0 - 34.0	27	5
18546/34	34.0 - 41.0	34	5
18546/41	41.0 - 49.0	41	5

DIE SET TABLE NC30

Pno	Crimp. range	D	L
702044/12	12.0 - 14.0	12	3
702044/14	14.0 - 16.0	14	3
702044/16	16.0 - 19.0	16	4
702044/19	19.0 - 22.0	19	4
702044/22	22.0 - 26.0	22	4.5
702044/26	26.0 - 30.0	26	4.5
702044/30	30.0 - 34.0	30	5
702044/34	34.0 - 39.0	34	5
702044/39	39.0 - 45.0	39	5
702044/45	45.0 - 51.0	45	5
702044/51	51.0 - 57.0	51	5
702044/57	57.0 - 63.0	57	5

DIE SET TABLE NC40

Pno	Crimp. range	D	L
703955/63	63.0 - 69.0	63	5
703955/69	69.0 - 73.0	69	5
703955/73	70.0 - 81.0	73	6
703955/81	81.0 - 93.0	81	7
703955/93	93.0 - 105.0	93	7

	NC30Z	NC40Z
Crimping range (mm) ¹⁾	12–63	12–105
Crimping range (inch) ¹⁾	0.47–2.48	0.47–4.13
Max opening (mm)	+26	+26
Max. crimping force (kN)	660	930
Max. crimping force (tonnage)	66	93
Number of crimpings/hour ²⁾	2 400	1 900
Motor (kW)	4	4
Motor (HP)	5.5	5.5
Weight (kg)	240	240
Weight (lbs)	529	529



<http://powerco.lillbacka.com/products/nut-cable-crimping>

1) With standard dies. Crimping range can be increased with special dies.

2) Theoretical with 10 mm opening. NC20, NC30 and NC40 dies can be used with NC40Z crimping machine